

Embedding in concrete with the LK Clip Rail Combi 16/20

DESIGN

ART. NO: 271 74 86, 271 74 87

- The LK Clip Rail Combi 16/20 is intended for use in single or double layer concrete structures and is suitable for pipes 16 and 20 mm in size 16 and c-t-c 160, 240 and 320 mm.
- The LK Clip Rail Combi 16/20 is 10.2 metres long and is supplied folded up. It is easy and fast to lay. Clip rails can be easily joined and extended. Material consumption 0.12 units/m².
- The LK Clip Rail Combi 16/20 is available in two versions and is made from recycled plastic. One version has inbuilt barbed staples and is intended for use when laying EPS insulation. The other version does not have barbed staples and is nailed or clipped in place in the slab using concrete nails and a nail gun.



LK Clip Rail Combi 16/20 on EPS insulation.



NOTE!
Read the instructions carefully before laying the LK Clip Rail Combi 16/20.



LK Clip Rail Combi 16/20 with barbed staples.

TABLE OF CONTENTS

Design	1
Installation requirements	1
Construction principle	2
Surface layer	2
Laying the clip rails	3
Laying the pipes	4
Product summary	5
Tools	5
Environment – recycling	5



INSTALLATION REQUIREMENTS



NOTE!

In general, the instructions apply in accordance with the HUS-AMA reference standard (Swedish Construction Industry Standard for house building) and for specified builders/quality managers.

The requirements for a properly functioning underfloor heating system are:

- A weather-controlled regulation system for the supply temperature.
- A well implemented and documented adjustment to the primary and loop flows.

CONSTRUCTION PRINCIPLE



NOTE!

The house's slab-on-ground floor must be dimensioned to take into account the house's load and comply with current regulations/standards.

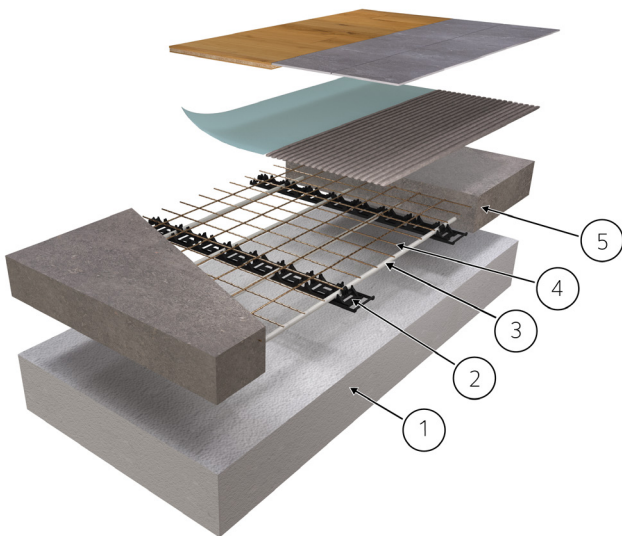

1. **Insulation/Concrete floor.**
2. **LK Clip Rail Combi 16/20.**
3. **Pipe.** LK Underfloor Heating Pipe dim. 16 mm or dim. 20 mm.
4. **Rebar.**
5. **Concrete.** A concrete thickness of at least 70 mm (45 mm above pipes) is recommended for the underfloor heating system to achieve as even a surface temperature as possible. Minimum acceptable concrete thickness is 55 mm (30 mm above pipes).

Insulation thickness

- The thickness of the insulation must be dimensioned to take into account the underfloor heating system.
- The compressive strength must be dimensioned to take into account the house's load.
- A rule of thumb for a standard house with slab-on-ground flooring is to use at least 250 mm thick insulation with a compressive strength of at least S100.

SURFACE LAYER

Vinyl, linoleum or carpets

Laid according to each supplier's instructions.

Parquet or laminate floor



NOTE!

Wooden flooring is laid according to flooring trade association's guidelines for wooden floors with underfloor heating. Seek advice from LK if the flooring thickness exceeds 25 mm.

The concrete surface must be covered with a vapour barrier (age-resistant plastic) and then with rag paper or cell foam. The upper floor is laid according to the supplier's instructions.

Ceramic tiling or natural stone



NOTE!

In wetroom areas, waterproofing must be installed in accordance with current requirements and local tile industry guidelines.

Laid according to each supplier's instructions.

Curing the concrete slab



NOTE!

It is of the utmost importance that the concrete slab is sufficiently cured before the upper floor is laid. A relative moisture measurement must be carried out according to HUS-AMA (Swedish Construction Industry Standard for house building).

The curing time can be shortened using the installed underfloor heating. The supply temperature should be maintained at approx. 5°C higher than the temperature in the concrete slab, but no more than 30°C. Find out the concrete's curing time before starting this drying method.

LK Manifold

The LK Manifold is fitted at the designated place according to drawing. Please read the assembly instructions enclosed with the manifold first.



LAYING THE CLIP RAILS

1. Lay the LK Clip Rail Combi 16/20 at right angles to the heating circuit.
 2. Where the circuit pipe turns, lay the rail approx. 300 mm from the wall, which provides the necessary space to bend the pipe.
 3. Fill in the remaining distance between the turning zones with additional rows of rails with a relative distance of approx. 1,000 mm.
- When installing over larger areas, for example in industrial premises, the spacing between the rails may be increased to a maximum of 1,500 mm. This requires that reinforcing mesh is installed above the pipes. If no reinforcing mesh is used, there is a risk that the pipes will float up during casting.
 - Where porous insulation made from cellular plastic, e.g. Isodrain is used, an extra reinforced fixture may be required. Use LK 90 mm Rail nails.

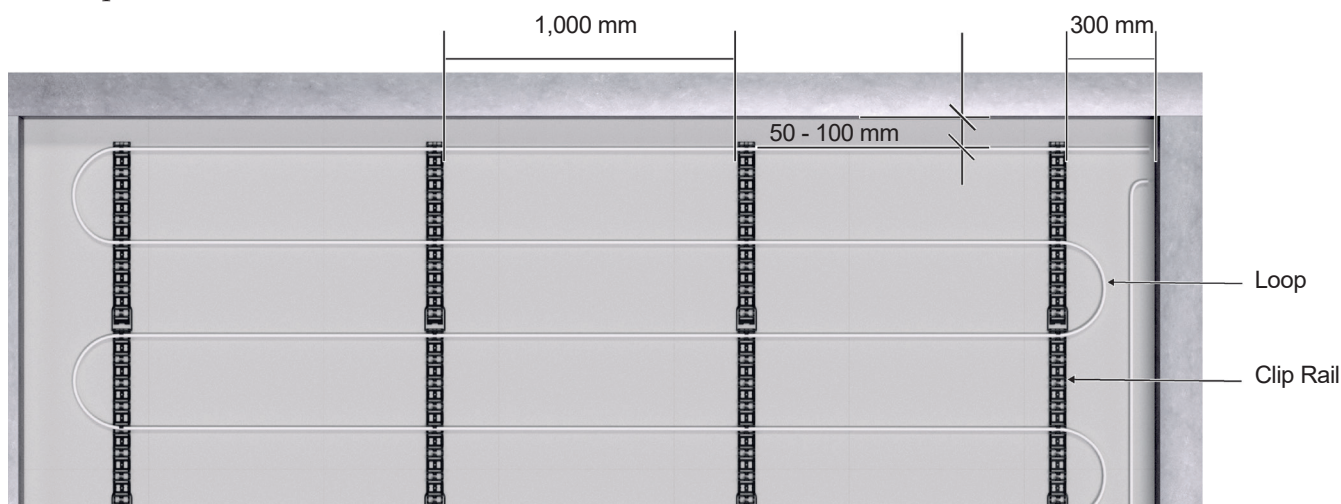

Laid rails and pipes from above with dimensions.



A fitter unfolds and inserts the rails in the EPS isolation.

LAYING THE PIPES

Tools and accessories

- Use the LK Pipe Decoiler as an accessory when laying pipes.
- The pipe can be held in place at the bend using the LK Pipe Holder.
- The LK 3D Premium staple gun with accompanying staples can be used to also attach the pipe at bends. For more information, see the *product overview* and *Tools* sections.
- To reinforce the edges, the pipe can be attached to the rebar with plastic cable ties.

Laying the pipes - Workflow



NOTE!

The drawing can show different pipe distances in different spaces. It is essential that differences in pipe distances are taken into account during installation.



NOTE!

Edge zones may occur, e.g. close to larger windows, and must then be taken into account during installation.



NOTE!

Do not lay the pipe closer than 100 mm from floor drains. A partial repair of the floor drain is possible if a sufficient distance is maintained.



NOTE!

Cut the pipe using pipe cutters designed for PE-X only.

1. Lay out the pipes according to the drawing.
2. Note the direction of flow in the loop so that the supply pipe runs along outer walls.
3. Number and name the loops as per the drawing.
4. Lay the pipe 50 to 100 mm from the inside of the outer wall.

Edge strip insulation

- Edge strip insulation must be used when pouring concrete along existing walls/support beams/pillars.
- The edge insulation takes up any expansion of the concrete and provides insulation.

Expansion areas

When pouring concrete in large areas, the work is made easier if the areas are divided into smaller sections. These smaller compartments are called expansion areas. An underfloor heating circuit should be laid within one and the same expansion area. Certain pipes (supply and return pipes) are run through the expansion joints between the expansion areas. These pipes must be protected with a protective conduit e.g. the LK Conduit.

- The total length of the protective conduit must be at least approx. 400 mm.
- The protective conduit is laid evenly with approx. 200 mm protective piping on each side of the expansion joint. In this way, this reduces any risk of damage that can occur during expansion movements between the concrete slabs.

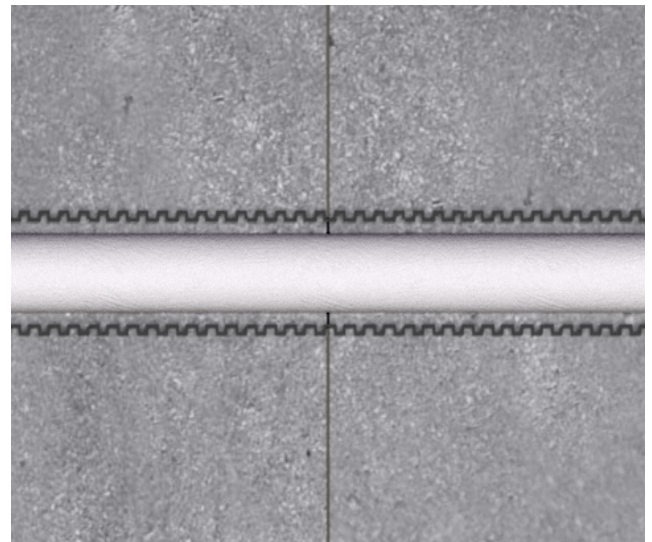

The picture shows an expansion joint.



PRODUCT SUMMARY

Art. No.	Length	Design
271 74 86	10,2 m	with barbed staples
271 74 87	10,2 m	without barbed staples

- For LK Underfloor Heating Pipes dim. 16 mm or dim. 20 mm.
- Intended for use where any additional insulation is provided.
- The LK Clip Rail Combi 16/20 is screwed, pushed or nailed in place. If necessary, rails can be clipped together to form longer rails.
- Material consumption 0.12 units/m².

Drawing Dimensions

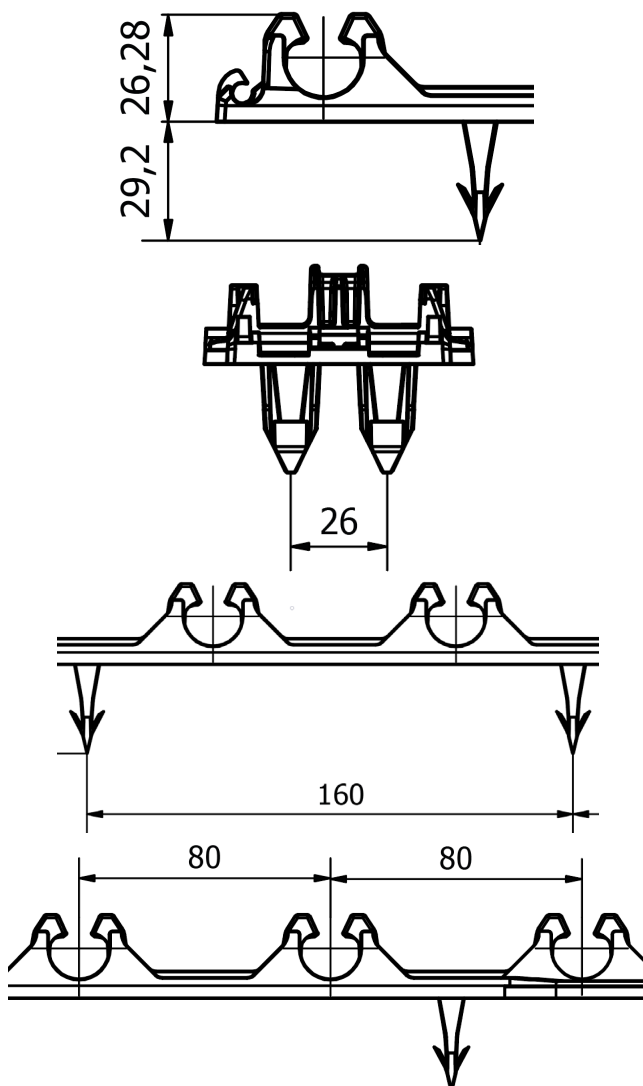

TOOLS

Art. No.	Name	Design
241 74 96	LK Pipe Decoiler	Suitable for 75-500 m
241 75 17/241 81 08	LK Pipe holder	LK Pipe holder bracket is intended for supplementary attachment if necessary.
298 88 17	LK Edge Strip	The LK edge strip is used to separate concrete from walls and other solid objects.
241 02 55	LK Rail Nail 90	The LK Rail Nail 90 is used to attach the clip rail to insulation boards made of cellular plastic, which both drains and insulates.
188 06 72	LK 3D Premium Staple gun	The LK 3D Premium Staple gun is used together with LK 3D Premium Staples for supplementary fastening of moldings or pipes.
188 06 71/243 49 98/33026	LK Staples	
188 25 14-18	LK Pipe Cutter	The LK Pipe Cutter is a top-quality pipe cutter when cutting PE-X and PAL piping. The LK Pipe Cutter is available in five sizes (8 to 63 mm).
187 06 65-66, 188 23 55	LK Conduit	Made of parallel corrugated PP as protective conduit to LK PEX and PAL pipes. The LK Conduit can also be used to reduce heat transmission in underfloor heating systems for the feeding pipes between the manifold and floor heating area

ENVIRONMENT – RECYCLING

When disposing of LK Clip Rail Combi 16/20, they must be sorted as plastic and combustible waste and handed over to a recycling station.

